

KOPIROVACIE FRÉZY



PANAS Tools s.r.o., Hradište 371, 95854 Hradište, SK
+421 (0)38 7496764-5, +421 (0) 38 7491373
panas@stonline.sk, www.panas.sk



FRÉZOVÁNÍ ROVINNÝCH PLOCH
FRÉZOVANIE ROVINNÝCH PLOCH

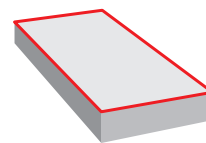

S45HN06C

45° $a_{p\max}$ [mm] 3,0
 $\varnothing D$ [mm] 25 - 125

ECON HN

HN 0604	P	M	K
XN 0604	N		H

14 - 19

S45HN09C

45° $a_{p\max}$ [mm] 5,0
 $\varnothing D$ [mm] 50 - 315

ECON HN

HN 0906	P	M	K
XN 0906	N		H

20 - 21

S45OD05D

45° $a_{p\max}$ [mm] 2,5 (7,3)
 $\varnothing D$ [mm] 40 - 125

OD.. 0504	P	M	K
	N		H

22 - 23

S45OD06D

45° $a_{p\max}$ [mm] 3,1 (8,6)
 $\varnothing D$ [mm] 63 - 160

OD.. 0605	P	M	K
RP.. 1505	N		H

24 - 25

S45SE09F

45° $a_{p\max}$ [mm] 4,5
 $\varnothing D$ [mm] 20 - 160

SE 09T3	P	M	K
	N	S	H

26 - 29

S45SN12Z

45° $a_{p\max}$ [mm] 6,5
 $\varnothing D$ [mm] 40 - 250

SN 1205	P	M	K
	N	S	H

30 - 31

S57PN13

57° $a_{p\max}$ [mm] 10,0
 $\varnothing D$ [mm] 100 - 315

PENTA HD

PN 1308	P	M	K
	N	S	H

32 - 33

C60HN09

60° $a_{p\max}$ [mm] 6,0
 $\varnothing D$ [mm] 80 - 250

ECON HN

HN 0905	P		K
			H

34 - 35

F60SB22X

60° $a_{p\max}$ [mm] 15,0
 $\varnothing D$ [mm] 125 - 315

ROUGH SB

SB 2207	P	M	K
			H

36 - 37

W60SP25P

60° $a_{p\max}$ [mm] 18,0
 $\varnothing D$ [mm] 125 - 315

SP 2506	P	M	K
		S	H

38 - 39

C90SC09

90° $a_{p\max}$ [mm] 0,5 (4,0)
 $\varnothing D$ [mm] 32 - 63

MULTISIDE SC

SC 09T3	P	M	K
	N	S	

40 - 43

C90SC12

90° $a_{p\max}$ [mm] 0,5 (6,0)
 $\varnothing D$ [mm] 32 - 80

MULTISIDE SC

SC 12T3	P	M	K
	N	S	

40 - 43

SMORC12

- $a_{p\max}$ [mm] 6,0
 $\varnothing D$ [mm] 40 - 100

RC 1204	P	M	K
	N	S	H

116 - 117

SMORC16

- $a_{p\max}$ [mm] 8,0
 $\varnothing D$ [mm] 63 - 100

RC 1606	P	M	K
	N	S	H

116 - 117

SMORC20

- $a_{p\max}$ [mm] 10,0
 $\varnothing D$ [mm] 80 - 100

RC 2006	P	M	K
	N	S	H

116 - 117

SRD05

- $a_{p\max}$ [mm] 1,5
 $\varnothing D$ [mm] 10 - 15

RD 0501	P	M	K
	N		H

120 - 121

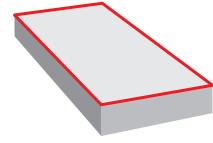
FRÉZOVÁNÍ ROVINNÝCH PLOCH
FRÉZOVANIE ROVINNÝCH PLOCHROVINNÉ FRÉZY
ROVINNÉ FRÉZYFRÉZY DO ROHU
FRÉZY DO ROHUVÁLCOVÉ/KOTOUČOVÉ FRÉZY
VALCOVÉ/KOTOUČOVÉ FRÉZYKOPIROVACÍ FRÉZY
KOPIROVACIE FRÉZYFRÉZY PRO SPEC. APLIKACE
FRÉZY PRE ŠPEC. APLIKÁCIEŘEZNÉ DOŠŤÍČKY
REZNÉ DOŠŤÍČKY

SRD07			
-	$a_{p\ max}$ [mm]	1,8	
	$\varnothing D$ [mm]	15 - 25	
	RD.. 07T1	P	M K
	RD.. 0702	N	H
118 - 121			

SRD10			
-	$a_{p\ max}$ [mm]	2,5	
	$\varnothing D$ [mm]	20 - 35	
	RD 1003	P	M K
		N	H
118 - 121			

S(C)RD12			
-	$a_{p\ max}$ [mm]	3,0	
	$\varnothing D$ [mm]	24 - 80	
	RD 12T3	P	M K
		N	H
120 - 123			

S(C)RD16			
-	$a_{p\ max}$ [mm]	4,0	
	$\varnothing D$ [mm]	32 - 100	
	RD 1604	P	M K
		N	H
120 - 123			

S19PD09			
19°	$a_{p\ max}$ [mm]	2	
	$\varnothing D$ [mm]	32 - 100	
	PD 0905	P	M K
		N	S H
126 - 127			

SZD07			
-	$a_{p\ max}$ [mm]	1	
	$\varnothing D$ [mm]	16 - 32	
	ZD 0703	P	M K
			H
128 - 131			

SZD09			
-	$a_{p\ max}$ [mm]	1	
	$\varnothing D$ [mm]	25 - 40	
	ZD 09T3	P	M K
			H
128 - 133			

SZD12			
-	$a_{p\ max}$ [mm]	1,6	
	$\varnothing D$ [mm]	32 - 80	
	ZD 1204	P	M K
			H
128 - 133			

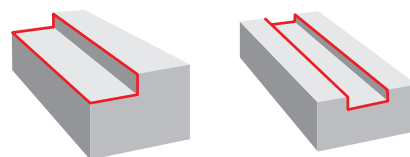
FRÉZOVÁNÍ NÍZKÝCH OSAZENÍ A DRÁŽEK
 FRÉZOVANIE NÍZKÝCH OSAZENÍ A DRÁŽOK

S90AD11E			S90AD16E			C90AD15			S90AP10D		
90°	$a_{p\max}$ [mm]	9,0	90°	$a_{p\max}$ [mm]	13,0	90°	$a_{p\max}$ [mm]	12,0	90°	$a_{p\max}$ [mm]	9,0
	$\varnothing D$ [mm]	16 - 125		$\varnothing D$ [mm]	25 - 160		$\varnothing D$ [mm]	40 - 80		$\varnothing D$ [mm]	10 - 63
FORCE AD			FORCE AD			MULTISIDE AD					
		AD 11T3		P M K N S H			AD 1606	P M K N S H			AD 15T3
		44 - 49			50 - 55			56 - 61			62 - 65
S90AP16D			S90LN12			S90LN16			S90SO09		
90°	$a_{p\max}$ [mm]	14,0	90°	$a_{p\max}$ [mm]	9,0	90°	$a_{p\max}$ [mm]	13,0	90°	$a_{p\max}$ [mm]	8,0
	$\varnothing D$ [mm]	25 - 160		$\varnothing D$ [mm]	25 - 110		$\varnothing D$ [mm]	63 - 175		$\varnothing D$ [mm]	20 - 125
			ECON LN			ECON LN					
		AP 1604		P M K N S H			LN 1205	P M K N H			LN 1607
		66 - 69			70 - 75			76 - 77			78 - 81
S90SD12			F90TB27X			W90SP25P			W90XO12		
90°	$a_{p\max}$ [mm]	10,0	90°	$a_{p\max}$ [mm]	18,0	90°	$a_{p\max}$ [mm]	22,0	90°	$a_{p\max}$ [mm]	10,0
	$\varnothing D$ [mm]	50 - 160		$\varnothing D$ [mm]	140 - 260		$\varnothing D$ [mm]	175 - 260		$\varnothing D$ [mm]	50 - 315
			ROUGH TB								
		SD 1205		P M K H			TB 2707	P M K H			SP 2506
		82 - 83			84 - 85			86 - 87			88 - 89

 ROVINNÉ FRÉZY
 ROVINNÉ FRÉZY

 FRÉZY DO ROHU
 FRÉZY DO ROHU

 VALCOVÉ/KOTUČOVÉ FRÉZY
 VALCOVÉ/KOTUČOVÉ FRÉZY

 KOPÍROVACÍ FRÉZY
 KOPÍROVACIE FRÉZY

 FRÉZY PRO SPEC. APLIKACE
 FRÉZY PRE ŠPEC. APLIKÁCIE

 ŘEZNÉ DESTIČKY
 REZNÉ DOŠTIČKY

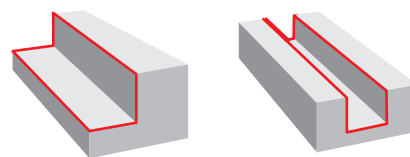
FRÉZOVÁNÍ HLUBOKÝCH OSAZENÍ A DRÁŽEK
FRÉZOVANIE HLBOKÝCH OSAZENÍ A DRÁŽOK**J-SAD11E**

90° $a_{p\max}$ [mm] 37,0 - 56,0
 ϕ D [mm] 25 - 50

FORCE AD

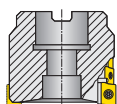

AD 11T3

P	M	K
N	S	H

90 - 93

C90SD12X

90° $a_{p\max}$ [mm] 44,0 - 87,0
 ϕ D [mm] 40 - 80

MULTISIDE SD



SD 1205

P	M	K
N	S	H

94 - 97

SLSN

90° $a_{p\max}$ [mm] 104,0 - 134,0
 ϕ D [mm] 63 - 80

ROUGH SN



SN 1305

P	K
	H

LN 1606

98 - 99

SSAP

90° $a_{p\max}$ [mm] 58,0 - 95,0
 ϕ D [mm] 50 - 63

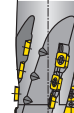

SP 1204

P	M	K
		H

AP 1504

100 - 101

SSAP-A

90° $a_{p\max}$ [mm] 58,0 - 95,0
 ϕ D [mm] 50 - 80

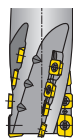

SP 1204

P	M	K
		H

AP 1504

102 - 103

2416-E

90° $a_{p\max}$ [mm] 40,0 - 63,0
 ϕ D [mm] 20 - 40



-

P	K

104

S90SN

90° $a_{p\max}$ [mm] 4,0 - 14,0
 ϕ D [mm] 80 - 200



SN 11

P	M	K
N	S	H

SN 12

106 - 108

S90SN-R

90° $a_{p\max}$ [mm] 4,0 - 12,0
 ϕ D [mm] 63 - 160

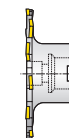

SN 11

P	M	K
N	S	H

SN 12

110 - 111

S90CN

90° $a_{p\max}$ [mm] 14,0 - 18,5
 ϕ D [mm] 125 - 315

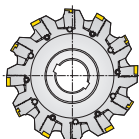

CN 1005

P	M	K
N	S	H

112 - 113

S90XN

90° $a_{p\max}$ [mm] 19,0 - 30,5
 ϕ D [mm] 160 - 315

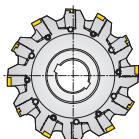

XN 1205

P	M	K
N	S	H

XN 1606

112 - 113

S90CN(XN)-R

90° $a_{p\max}$ [mm] 14,0 - 18,5
 ϕ D [mm] 125 - 200

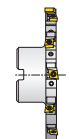

CN 1005

P	M	K
N	S	H

114 - 115

S90CN(XN)-R

90° $a_{p\max}$ [mm] 19,0 - 30,5
 ϕ D [mm] 160 - 200

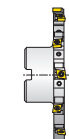

XN 1205

P	M	K
N	S	H

XN 1606

114 - 115

S19PD09

19° $a_{p\max}$ [mm] 2,0
 ϕ D [mm] 32 - 100

PENTA HF

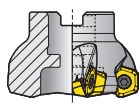

PD 0905

P	M	K
N	S	H

124 - 127

SZD07

- $a_{p\max}$ [mm] 1,0
 ϕ D [mm] 16 - 32

FEED ZD



ZD 0703

P	M	K
		H

128 - 131

SZD09

- $a_{p\max}$ [mm] 1,0
 ϕ D [mm] 25 - 40

FEED ZD



ZD 09T3

P	M	K
		H

128 - 133

SZD12

- $a_{p\max}$ [mm] 1,6
 ϕ D [mm] 32 - 80

FEED ZD

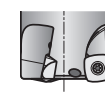

ZD 1204

P	M	K
		H

128 - 133

FRÉZOVÁNÍ TVAROVÝCH PLOCH (KOPIROVACÍ FRÉZY)
FRÉZOVANIE TVAROVÝCH PLŔCH (KOPIROVACIE FRÉZY)

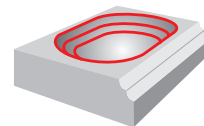
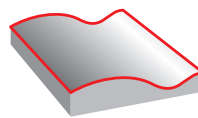

SMORC12

-	$a_{p\ max}$ [mm]	6,0
	$\varnothing D$ [mm]	40 - 100

	RC 1204	P	M	K
		N	S	H

116 - 117

SMORC16

-	$a_{p\ max}$ [mm]	8,0
	$\varnothing D$ [mm]	63 - 100

	RC 1606	P	M	K
		N	S	H

116 - 117

SMORC20

-	$a_{p\ max}$ [mm]	10,0
	$\varnothing D$ [mm]	80 - 100

	RC 2006	P	M	K
		N	S	H

116 - 117

SRD05

-	$a_{p\ max}$ [mm]	1,5
	$\varnothing D$ [mm]	10 - 15

	RD 0501	P	M	K
		N		H

120 - 121

SRD07

-	$a_{p\ max}$ [mm]	1,8
	$\varnothing D$ [mm]	15 - 25

	RD.. 07T1	P	M	K
	RD.. 0702	N		H

118 - 121

SRD10

-	$a_{p\ max}$ [mm]	2,5
	$\varnothing D$ [mm]	20 - 35

	RD 1003	P	M	K
		N		H

118 - 121

S(C)RD12

-	$a_{p\ max}$ [mm]	3,0
	$\varnothing D$ [mm]	24 - 80

	RD 12T3	P	M	K
		N		H

120 - 123

S(C)RD16

-	$a_{p\ max}$ [mm]	4,0
	$\varnothing D$ [mm]	32 - 100

	RD 1604	P	M	K
		N		H

120 - 123

S19PD09

19°	$a_{p\ max}$ [mm]	2,0
	$\varnothing D$ [mm]	32 - 100

PENTA HF

	PD 0905	P	M	K
		N	S	H

124 - 127

SZD07

-	$a_{p\ max}$ [mm]	1,0
	$\varnothing D$ [mm]	16 - 32

FEED ZD

	ZD 0703	P	M	K
				H

128 - 131

SZD09

-	$a_{p\ max}$ [mm]	1,0
	$\varnothing D$ [mm]	25 - 40

FEED ZD

	ZD 09T3	P	M	K
				H

128 - 133

SZD12

-	$a_{p\ max}$ [mm]	1,6
	$\varnothing D$ [mm]	32 - 80

FEED ZD

	ZD 1204	P	M	K
				H

128 - 133

SZP10

-	$a_{p\ max}$ [mm]	8,9
	$\varnothing D$ [mm]	10

	ZP 10	P	M	K
			S	H

134 - 139

SZP12

-	$a_{p\ max}$ [mm]	10,7
	$\varnothing D$ [mm]	12

	ZP 12	P	M	K
		N	S	H

134 - 139

SZP16

-	$a_{p\ max}$ [mm]	14,4
	$\varnothing D$ [mm]	16

	ZP 16	P	M	K
		N	S	H

134 - 139

SZP20

-	$a_{p\ max}$ [mm]	17,9
	$\varnothing D$ [mm]	20

	ZP 20	P	M	K
		N	S	H

134 - 139

ROVINNÉ FRÉZY
ROVINNÉ FRÉZY

FRÉZY DO ROHU
FRÉZY DO ROHU

VÁLCOVÉ/KOTUČOVÉ FRÉZY
VÁLCOVÉ/KOTUČOVÉ FRÉZY

KOPIROVACÍ FRÉZY
KOPIROVACIE FRÉZY

FRÉZY PRO SPEC. APLIKACE
FRÉZY PRE ŠPEC. APLIKÁCIE

ŘEZNÉ DESTIČKY
ŘEZNÉ DOŠTIČKY

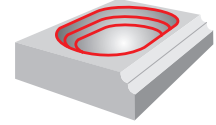
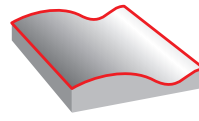
FRÉZOVÁNÍ TVAROVÝCH PLOCH (KOPIROVACÍ FRÉZY)
FRÉZOVANIE TVAROVÝCH PLŔCH (KOPIROVACIE FRÉZY)
**SZP25**

-	$a_{p\max}$ [mm]	22,3
	$\varnothing D$ [mm]	25



ZP 25

P	M	K
N	S	H

134 - 139

SZP32

-	$a_{p\max}$ [mm]	28,6
	$\varnothing D$ [mm]	32



ZP 32

P	M	K
N	S	H

134 - 136

SZP40

-	$a_{p\max}$ [mm]	35,7
	$\varnothing D$ [mm]	40



ZP 40

P	M	K
N	S	H

134 - 136

SZP50

-	$a_{p\max}$ [mm]	44,7
	$\varnothing D$ [mm]	50



ZP 50

P	M	K
N	S	H

134 - 136

CXP16

-	$a_{p\max}$ [mm]	8,0
	$\varnothing D$ [mm]	16



MULTISIDE XP



XP 16

P	M	K
S	H	

140 - 143

CXP20

-	$a_{p\max}$ [mm]	10,0
	$\varnothing D$ [mm]	20



MULTISIDE XP



XP 20

P	M	K
S	H	

140 - 143

CXP25

-	$a_{p\max}$ [mm]	12,5
	$\varnothing D$ [mm]	25



MULTISIDE XP



XP 25

P	M	K
S	H	

140 - 143

CXP32

-	$a_{p\max}$ [mm]	16,0
	$\varnothing D$ [mm]	32



MULTISIDE XP



XP 32

P	M	K
S	H	

140 - 143

S90VC22C

90°	$a_{p\max}$ [mm]	16,0
	$\varnothing D$ [mm]	32 - 80

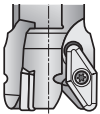

VC 220530

N		
---	--	--

144 - 149

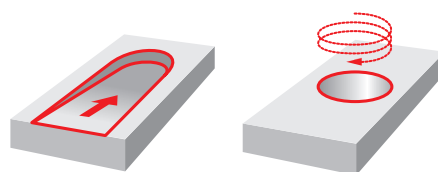
ZAJÍŽDĚNÍ POD ÚHLEM
 ZACHÁDZANIE POD UHLOM

SMORC12			SMORC16			SMORC20			SRD05		
-	$a_{p\ max}$ [mm]	6,0	-	$a_{p\ max}$ [mm]	8,0	-	$a_{p\ max}$ [mm]	10,0	-	$a_{p\ max}$ [mm]	1,5
	$\varnothing D$ [mm]	40 - 100		$\varnothing D$ [mm]	63 - 100		$\varnothing D$ [mm]	80 - 100		$\varnothing D$ [mm]	10 - 15
	RC 1204	P M K N S H		RC 1606	P M K N S H		RC 2006	P M K N S H		RD 0501	P M K N S H
		116 - 117			116 - 117			116 - 117			120 - 121
SRD07			SRD10			S(C)RD12			S(C)RD16		
-	$a_{p\ max}$ [mm]	1,8	-	$a_{p\ max}$ [mm]	2,5	-	$a_{p\ max}$ [mm]	3,0	-	$a_{p\ max}$ [mm]	4,0
	$\varnothing D$ [mm]	15 - 25		$\varnothing D$ [mm]	20 - 35		$\varnothing D$ [mm]	24 - 80		$\varnothing D$ [mm]	32 - 100
	RD.. 07T1 RD.. 0702	P M K N S H		RD 1003	P M K N S H		RD 12T3	P M K N S H		RD 1604	P M K N S H
		118 - 121			118 - 121			120 - 123			120 - 123
S19PD09			SZD07			SZD09			SZD12		
19°	$a_{p\ max}$ [mm]	2,0	-	$a_{p\ max}$ [mm]	1,0	-	$a_{p\ max}$ [mm]	1,0	-	$a_{p\ max}$ [mm]	1,6
	$\varnothing D$ [mm]	32 - 100		$\varnothing D$ [mm]	16 - 32		$\varnothing D$ [mm]	25 - 40		$\varnothing D$ [mm]	32 - 80
PENTA HF			FEED ZD			FEED ZD			FEED ZD		
	PD 0905	P M K N S H		ZD 0703	P M K N S H		ZD 09T3	P M K N S H		ZD 1204	P M K N S H
		124 - 127			128 - 131			128 - 133			128 - 133
S90AD11E			S90AD16E			C90AD15			S90AP10D		
90°	$a_{p\ max}$ [mm]	9,0	90°	$a_{p\ max}$ [mm]	13,0	90°	$a_{p\ max}$ [mm]	12,0	90°	$a_{p\ max}$ [mm]	9,0
	$\varnothing D$ [mm]	16 - 125		$\varnothing D$ [mm]	25 - 160		$\varnothing D$ [mm]	40 - 80		$\varnothing D$ [mm]	10 - 63
FORCE AD			FORCE AD			MULTISIDE AD					
	AD 11T3	P M K N S H		AD 1606	P M K N S H		AD 15T3	P M K N S H		AP 1003	P M K N S H
		44 - 49			50 - 55			56 - 61			62 - 65

 ROVINNÉ FRÉZY
 ROVINNÉ FRÉZY

 FRÉZY DO ROHU
 FRÉZY DO ROHU

 VÁLCOVÉ/KOTUČOVÉ FRÉZY
 VÁLCOVÉ/KOTUČOVÉ FRÉZY

 KOPÍROVACÍ FRÉZY
 KOPÍROVACÍ FRÉZY

 FRÉZY PRO SPEC. APLIKACE
 FRÉZY PRE ŠPEC. APLIKÁCIE

 ŘEZNÉ DESTIČKY
 ŘEZNÉ DOŠTIČKY

ZAJÍŽDĚNÍ POD ÚHLEM ZACHÁDZANIE POD UHLOM

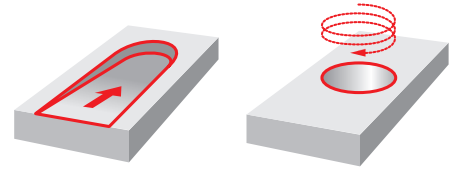

S90AP16D

90°	$a_{p\ max}$ [mm]	14,0
	$\varnothing D$ [mm]	25 - 160

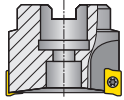

AP 1604

P	M	K
N	S	H

66 - 69

S90LN12

90°	$a_{p\ max}$ [mm]	9,0
	$\varnothing D$ [mm]	25 - 110

ECON LN

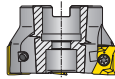

LN 1205

P	M	K
N		H

70 - 75

S90VC22C

90°	$a_{p\ max}$ [mm]	16,0
	$\varnothing D$ [mm]	32 - 80

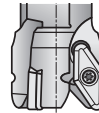

VC 220530

N		

144 - 149

S45HN06C

45°	$a_{p\ max}$ [mm]	3,0
	$\varnothing D$ [mm]	25 - 125

ECON HN

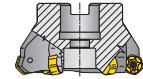

HN 0604

P	M	K
N		H

14 - 19

S45HN09C

45°	$a_{p\ max}$ [mm]	5,0
	$\varnothing D$ [mm]	50 - 315

ECON HN

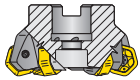

HN 0906

P	M	K
N		H

20 - 21

SRÁŽENÍ HRAN, ÚKOSY A T-DRÁŽKY
ZRAŽANIE HRÁN, ÚKOSY A T-DRÁŽKY

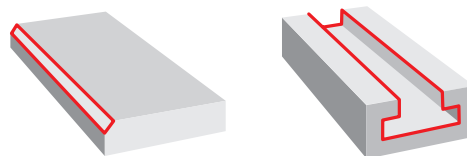

SSD09

45°	$a_{p\ max}$ [mm]	4,5
	$\varnothing D$ [mm]	10 - 25

SD 0903	P	M	K
	N	S	H

150 - 151

N-SSO09

45°	$a_{p\ max}$ [mm]	4,5
	$\varnothing D$ [mm]	8 - 25

SO 09T3	P	M	K
	N	S	H

152 - 153

2516

45°	$a_{p\ max}$ [mm]	8,5
	$\varnothing D$ [mm]	11 - 19

TC 16T3	P	M	K
	N	S	H

154 - 155

2636

10-80°	$a_{p\ max}$ [mm]	8,5
	$\varnothing D$ [mm]	11 - 19

TC 16T3	P	M	K
	N	S	H

156 - 157

SxxXP

15-75°	$a_{p\ max}$ [mm]	7,0 - 28,0
	$\varnothing D$ [mm]	35 - 45

XP 1604	P	M	K
	N	S	

158 - 159

SCC06

90°	$a_{p\ max}$ [mm]	11,0
	$\varnothing D$ [mm]	25

CC 0603	P	M	K
		S	

160 - 161

SSC08

90°	$a_{p\ max}$ [mm]	14,0
	$\varnothing D$ [mm]	32

CC 08T3	P	M	K
		S	

160 - 161

SSC09

90°	$a_{p\ max}$ [mm]	18,0
	$\varnothing D$ [mm]	40

CC 09T3	P	M	K
		S	

160 - 161

ROVINNÉ FRÉZY
ROVINNÉ FRÉZY

FRÉZY DO ROHU
FRÉZY DO ROHU

VALCOVÉ/KOTUČOVÉ FRÉZY
VALCOVÉ/KOTUČOVÉ FRÉZY

KOPIROVACÍ FRÉZY
KOPIROVACIE FRÉZY

FRÉZY PRO SPEC. APLIKACE
FRÉZY PRE ŠPEC. APLIKÁCIE

ŘEZNÉ DOŠŤÍČKY
REZNÉ DOŠŤÍČKY

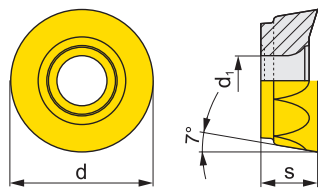

RCMT

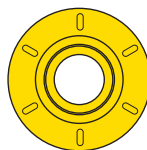

RCMT-F

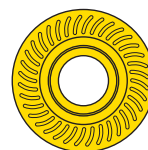

RCMT-M

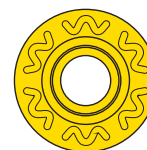

RCMT-R

VYMĚNITELNÉ BŘITOVÉ DESTIČKY / VYMENITELNÉ REZNÉ DOŠTIČKY

ISO	Materiály								Rozměry / Rozmery					
	M9315	M9325	M9340	M8310	M8345	8215	8230	8240	d	s	d ₁			
RCMT 1204MOEN-F				■	■	■			12,000	4,760	4,40			
RCMT 1204MOEN-R			■				■		12,000	4,760	4,40			
RCMT 1204MOSN-M	■	■			■	■			12,000	4,760	4,40			
RCMT 1204MOSN-R					■				12,000	4,760	4,40			
RCMT 1606MOEN-F				■				■	16,000	6,350	5,50			
RCMT 1606MOSN-M		■	■		■	■			16,000	6,350	5,50			
RCMT 1606MOSN-R					■				16,000	6,350	5,50			
RCMT 2006MOSN-M	■	■	■		■	■			20,000	6,350	6,50			
RCMT 2006MOSN-R					■				20,000	6,350	6,50			

NÁHRADNÍ DÍLY / NÁHRADNÉ DIELY

*) Utahovací momenty viz strana / Utahovacie momenty viď strana: 318 - 321.

Označení frézy Označenie frézy	Upínací šroub* Upínacia skrutka*	Dřík Driek	Rukojeť Rukoväť	Šroubovák Skrutkovač	Šroub pro upnutí na tm Skrutka pre upnutie na tm
40A03R-SMORC12	US 63509-T15P	D-T08P/T15P	FG-15	-	HS 90835
50A04R-SMORC12	US 63509-T15P	D-T08P/T15P	FG-15	-	HS 1030C
63A05R-SMORC12	US 63509-T15P	D-T08P/T15P	FG-15	-	HS 1030C
80A05R-SMORC12	US 63509-T15P	D-T08P/T15P	FG-15	-	-
100A06R-SMORC12	US 63509-T15P	D-T08P/T15P	FG-15	-	-
63A04R-SMORC16	US 65014-T20P	-	-	SDR T20P-T	HS 1030C
80A05R-SMORC16	US 65014-T20P	-	-	SDR T20P-T	-
100A06R-SMORC16	US 65014-T20P	-	-	SDR T20P-T	-
80A04R-SMORC20	US 66015-T25P	-	-	SDR T25P-T	HS 1230C
100A05R-SMORC20	US 66015-T25P	-	-	SDR T25P-T	-

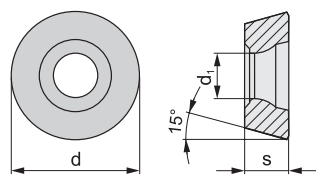

RD..

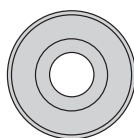

RDHX MOT

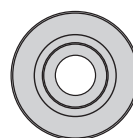

RDGX MOT

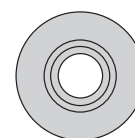

RDHT-FA

VYMĚNITELNÉ BŘITOVÉ DESTIČKY / VYMENITELNÉ REZNÉ DOŠTIČKY

ISO	Materiály										Rozměry / Rozmery						
	M9340	M8310	M8325	M8345	7205	7010	7025	7040	5040	HF7	d	d ₁	s				
RDHX 0702MOT		■	■		●	○	○				7,000	2,80	2,38				
RDHX 1003MOT		■	■	■	●	○	○	○	○		10,000	3,90	3,18				
RDGT 0702MOT		□	□	□		○	○	○			7,000	2,80	2,38				
RDGT 1003MOT	●	□	■	■		○	○	○			10,000	3,90	3,18				
RDHT 0702MO-FA									●		7,000	2,80	2,38				
RDHT 1003MO-FA									●		10,000	3,90	3,18				

NÁHRADNÍ DÍLY / NÁHRADNÉ DIELY

*) Uťahovací momenty viz strana / Uťahovacie momenty viď strana: 318 - 321.

Označení frézy Označenie frézy	Upínací šroub* Upínacia skrutka*	Šroubovák Skrutkovač
..SRD07	US 25	SDR T07
..SRD10	US 3507-T15	SDR T15

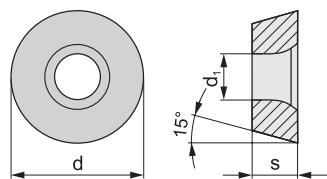

RD..

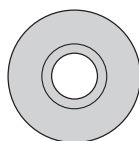

RDHX MOE

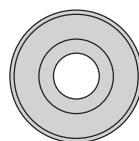

RDHX MOT

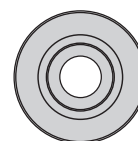

RDGX MOT

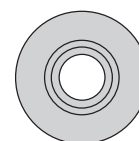

RDHT-FA

VYMĚNITELNÉ BŘITOVÉ DESTIČKY / VYMENITELNÉ REZNÉ DOŠTIČKY

ISO	Materiály										Rozměry / Rozmery										
	M9340	M8310	M8325	M8345	7205	7010	7025	7040	5040	HF7					d	d ₁	s				
RDHX 0501MOE		■				○									5,000	2,20	1,51				
RDHX 07T1MOT		■	□			○	○								7,000	2,80	1,98				
RDHX 0702MOT		■	■		●	○	○								7,000	2,80	2,38				
RDHX 1003MOT		■	■	■	●	○	○	○	○						10,000	3,90	3,18				
RDHX 12T3MOT		■	■	■	●	○	○	○	○						12,000	3,90	3,97				
RDHX 1604MOT		■	■	■		○	○	○	○						16,000	5,20	4,76				
RDGT 0702MOT		□	□	□		○	○	○							7,000	2,80	2,38				
RDGT 1003MOT		●	□	■	■	○	○	○							10,000	3,90	3,18				
RDGT 12T3MOT		●	■	■	■	○	○	○							12,000	3,90	3,97				
RDGT 1604MOT		●	□	■	■	○	○	○							16,000	5,20	4,76				
RDHT 07T1MO-FA									○						7,000	2,80	1,98				
RDHT 0702MO-FA									●						7,000	2,80	2,38				
RDHT 1003MO-FA									●						10,000	3,90	3,18				
RDHT 12T3MO-FA									●						12,000	3,90	3,97				
RDHT 1604MO-FA									○						16,000	5,20	4,76				

NÁHRADNÍ DÍLY / NÁHRADNÉ DIELY

*) Uťahovací momenty viz strana / Uťahovacie momenty viď strana: 318 - 321.

Označení frézy Označenie frézy	Upínací šroub* Upínacia skrutka*	Upínací šroub Upínacia skrutka	Upínka	Šroubovák Skrutkovač
..SRD05	US 20	-	-	SDR T06
..SRD07	US 25	-	-	SDR T07
..SRD10	US 3507-T15	-	-	SDR T15
..SCRD12	US 3507-T15	CS12	-	SDR T15
..SRD12	US 3507-T15	-	-	SDR T15
..SCRD16	US 4511-T20	-	LA 12T3	SDR T20
..SRD16	US 4511-T20	-	-	SDR T20

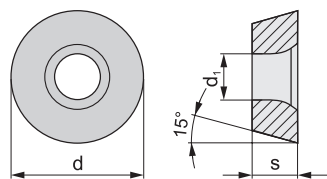

RD..

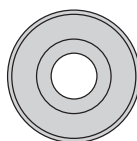

RDHX MOT

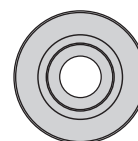

RDGX MOT

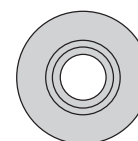

RDHT-FA

ROVINNÉ FRÉZY
ROVINNÉ FRÉZY

VYMĚNITELNÉ BŘITOVÉ DESTIČKY / VYMNITELNÉ REZNÉ DOŠTIČKY

ISO	Materiály										Rozměry / Rozmery						
	M9340	M8310	M8325	M8345	7205	7010	7025	7040	5040	HF7	d	d ₁	s				
RDHX 12T3MOT		■	■	■	●	○	○	○	○		12,000	3,90	3,97				
RDHX 1604MOT		■	■	■		○	○	○	○		16,000	5,20	4,76				
RDGT 12T3MOT	●	■	■	■		○	○	○			12,000	3,90	3,97				
RDGT 1604MOT	●	□	■	■		○	○	○			16,000	5,20	4,76				
RDHT 12T3MO-FA									●		12,000	3,90	3,97				
RDHT 1604MO-FA									○		16,000	5,20	4,76				

FRÉZY DO ROHU
FRÉZY DO ROHU

VÁLCOVÉ/KOTUČOVÉ FRÉZY
VÁLCOVÉ/KOTUČOVÉ FRÉZY

KOPIROVACÍ FRÉZY
KOPIROVACIE FRÉZY

FRÉZY PRO SPEC. APLIKACE
FRÉZY PRE ŠPEC. APLIKÁCIE

ŘEZNÉ DESTIČKY
REZNÉ DOŠTIČKY

NÁHRADNÍ DÍLY / NÁHRADNÉ DIELY

*) Uťahovací momenty viz strana / Uťahovacie momenty viď strana: 318 - 321.

Označení frézy Označenie frézy	Upínací šroub* Upínacia skrutka*	Upínací šroub Upínacia skrutka	Upínka	Šroubovák Skrutkovač
..SCMORD12	US 3507-T15	CS 12	-	SDR T15
..SCMORD16	US 4511-T20	-	LA 12T3	SDR T20

SPD09

STOPKOVÉ FRÉZY PRO FRÉZOVÁNÍ VYSOKÝMI POSUVY STOPKOVÉ FRÉZY PRE FRÉZOVANIE VYSOKÝMI POSUVMI

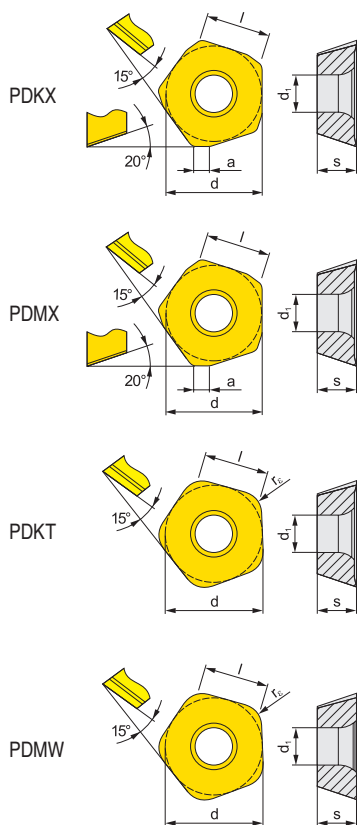

PDKX-FM



PDMX-M



PDMX-R



PDKT-FM

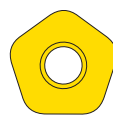

PDMW

VYMĚNITELNÉ BŘITOVÉ DESTIČKY / VYMENITELNÉ REZNÉ DOŠTIČKY

ISO	Materiály					Dimensions [mm]					
	M9325	M9340	M8345	8215	8230	l	d	s	d ₁	a	r _c
PDKX 0905ZEER-FM		■	■			9,00	13,50	5,47	5,50	2,00	-
PDMX 0905ZEER-M		■	■	■	■	9,00	13,50	5,47	5,50	2,00	-
PDMX 0905ZESR-R			■	■	■	9,00	13,50	5,47	5,50	2,00	-
PDKT 090530ER-FM			■	■	■	9,00	13,50	5,47	5,50	-	3,0
PDMW 090530SR	■	■				9,00	13,50	5,47	5,50	-	3,0

NÁHRADNÍ DÍLY / NÁHRADNÉ DIELY

*) Uťahovací momenty viz strana / Uťahovacie momenty viď strana: 318 - 321.

Fréza průměr Fréza priemer	Upínací šroub* Upínacia skrutka*	Šroubovák Skrutkovač
32 ÷ 40	US 45011-T20P	FLAG T20P

S19PD09

NÁSTRČNÉ FRÉZY PRO FRÉZOVÁNÍ VELKÝMI POSUVY NÁSTRČNÉ FRÉZY PRE FRÉZOVANIE VEĽKÝMI POSUVMI

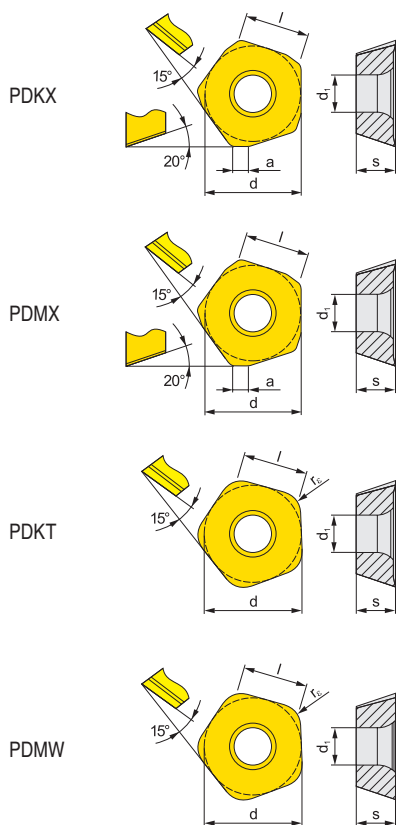

PDKX-FM



PDMX-M



PDMX-R



PDKT-FM



PDMW

VYMĚNITELNÉ BŘITOVÉ DESTIČKY / VYMENITELNÉ REZNÉ DOŠTIČKY

ISO	Materiály						Rozměry / Rozmery					
	M9325	M9340	M8345	8215	8230	8240	l	d	s	d ₁	a	r _c
PDKX 0905ZEER-FM	■	■					9,00	13,50	5,47	5,50	2,0	-
PDMX 0905ZEER-M	■	■	■	■			9,00	13,50	5,47	5,50	2,0	-
PDMX 0905ZESR-R			■	■	■		9,00	13,50	5,47	5,50	2,0	-
PDKT 090530ER-FM			■	■	■		9,00	13,50	5,47	5,50	-	3,0
PDMW 090530SR	■	■					9,00	13,50	5,47	5,50	-	3,0

NÁHRADNÍ DÍLY / NÁHRADNÉ DIELY

*) Uťahovací momenty viz strana / Uťahovacie momenty viď strana: 318 - 321.

Fréza průměr Fréza priemer	Upínací šroub* Upínacia skrutka*	Šroubovák Skrutkovač	Šroub pro upnutí na trn Skrutka pre upnutie na trn
42	US 45011-T20P	SDR T20P-T	HS 90835
50 ÷ 66	US 45011-T20P	SDR T20P-T	HS 1030C
80 ÷ 100	US 45011-T20P	SDR T20P-T	-

L2-SZP

KOPÍROVACÍ FRÉZY
KOPÍROVACIE FRÉZY

γ_p	-10°	κ_r	-
γ_f	0°	$a_{p\max}$	-

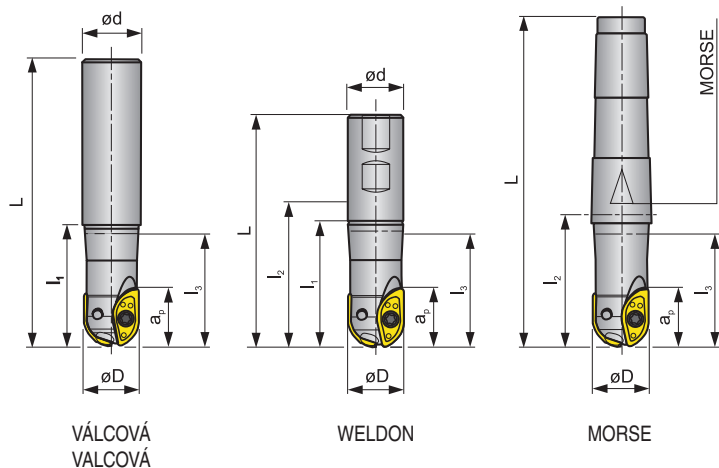
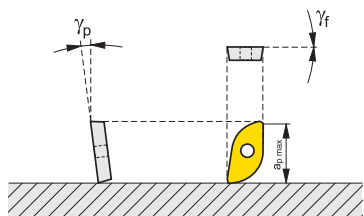

Z* - Počet zubů / Počet zubov

Všechny rozměry v [mm]. / Všetky rozmery v [mm].

ISO	Sortiment	Rozměry / Rozmery										Chlazení Chladienie	[kg]
		D	L	l_1	l_2	l_3	d	Morse	Z*	VBD VRD	$a_{p\max}$		
VALCOVÁ/VALCOVÁ													
10L2R050A16-SZP10	■	10	160	50,0	-	22,3	16	-	2	ZP 10..	8,9		0,21
12L2R045A20-SZP12	■	12	200	44,8	-	22,0	20	-	2	ZP 12..	10,7		0,43
16L2R045A20-SZP16-C	■	16	200	44,5	-	29,4	20	-	2	ZP 16..	14,4	+	0,43
20L2R050A20-SZP20-C	■	20	250	50,0	-	-	20	-	2	ZP 20..	17,9	+	0,85
20L2R055A25-SZP20-C	■	20	200	54,4	-	36,1	25	-	2	ZP 20..	17,9	+	0,65
20L2R055A32-SZP20-C	■	20	250	55,7	-	34,5	32	-	2	ZP 20..	17,9	+	1,40
25L2R060A25-SZP25-C	■	25	250	60,0	-	-	25	-	2	ZP 25..	22,3	+	1,29
25L2R065A32-SZP25-C	■	25	250	64,7	-	43,0	32	-	2	ZP 25..	22,3	+	1,29
32L2R070A32-SZP32-C	■	32	250	70,3	-	-	32	-	2	ZP 32..	28,6	+	1,37
WELDON													
12L2R040B20-SZP12	□	12	91	40	66,5	21,5	20	-	2	ZP 12..	10,7		0,16
12L2R060B20-SZP12	■	12	111	60	86,5	23,8	20	-	2	ZP 12..	10,7		0,19
16L2R040B20-SZP16-C	■	16	91	40	66,5	28,3	20	-	2	ZP 16..	14,4	+	0,16
16L2R060B20-SZP16-C	■	16	111	60	86,5	32,9	20	-	2	ZP 16..	14,4	+	0,20
20L2R050B25-SZP20-C	■	20	107	50	75,5	35,1	25	-	2	ZP 20..	17,9	+	0,29
20L2R070B25-SZP20-C	■	20	127	70	95,5	39,5	25	-	2	ZP 20..	17,9	+	0,35
25L2R060B25-SZP25-C	■	25	117	60	85,5	-	25	-	2	ZP 25..	22,3	+	0,35
25L2R080B25-SZP25-C	■	25	137	80	105,0	-	25	-	2	ZP 25..	22,3	+	0,41
32L2R070B32-SZP32-C	■	32	131	70	95,5	-	32	-	2	ZP 32..	28,6	+	0,62
32L2R100B32-SZP32-C	■	32	161	100	125,5	-	32	-	2	ZP 32..	28,6	+	0,79
40L2R070B32-SZP40-C	■	40	131	70	95,5	-	32	-	2	ZP 40..	35,7	+	0,72
40L2R100B40-SZP40-C	■	40	171	100	131,0	-	40	-	2	ZP 40..	35,7	+	1,33
50L2R100B50-SZP50-C	□	50	181	100	136,5	-	50	-	2	ZP 50..	44,7	+	2,13

ISO	Sortiment	Rozměry / Rozmery										Chlazení Chladienie	[kg]
		D	L	l_1	l_2	l_3	d	Morse	Z	VBD VRD	a_{pmax}		
MORSE													
10L2R050E02-SZP10	■	10	114	-	50	21,9	-	2	2	ZP 10..	8,9	0,12	
12L2R040E02-SZP12	■	12	104	-	40	22,5	-	2	2	ZP 12..	10,7	0,11	
12L2R060E02-SZP12	■	12	124	-	60	25,8	-	2	2	ZP 12..	10,7	0,14	
12L2R090E02-SZP12	■	12	154	-	90	25,8	-	2	2	ZP 12..	10,7	0,19	
16L2R040E02-SZP16	□	16	104	-	40	31,3	-	2	2	ZP 16..	14,4	0,12	
16L2R060E02-SZP16	■	16	124	-	60	42,2	-	2	2	ZP 16..	14,4	0,15	
16L2R090E02-SZP16	■	16	154	-	90	75,9	-	2	2	ZP 16..	14,4	0,19	
20L2R050E03-SZP20	□	20	131	-	50	36,6	-	3	2	ZP 20..	17,9	0,27	
20L2R070E03-SZP20	■	20	151	-	70	-	-	3	2	ZP 20..	17,9	0,33	
20L2R100E03-SZP20	■	20	181	-	100	77,4	-	3	2	ZP 20..	17,9	0,39	
25L2R080E03-SZP25	■	25	161	-	80	-	-	3	2	ZP 25..	22,3	0,39	
25L2R110E04-SZP25	■	25	213	-	110	92,7	-	4	2	ZP 25..	22,3	0,76	
32L2R100E04-SZP32	■	32	203	-	100	-	-	4	2	ZP 32..	28,6	0,83	
32L2R150E04-SZP32	■	32	253	-	150	-	-	4	2	ZP 32..	28,6	1,10	
50L2R100E05-SZP50	□	50	230	-	100	-	-	5	2	ZP 50..	44,7	2,00	

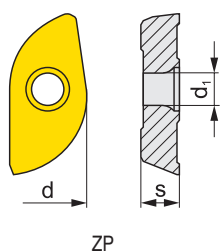

ZP



ZP-F



ZP-FM



ZP-M



ZP-R

VYMĚNITELNÉ BŘITOVÉ DESTIČKY / VYMENITELNÉ REZNÉ DOŠTIČKY

ISO	Materiály				Rozměry / Rozmery		
	M8310	M8345	8230	8240	d	s	d_1
ZP 20ER-F	■				20,00	3,97	4,0
ZP 50ER-F	□				50,00	7,94	9,6
ZP 10ER-FM	■	■			10,00	1,70	2,2
ZP 12ER-FM	■	■			12,00	2,38	2,9
ZP 16ER-FM	■	■			16,00	3,18	2,9
ZP 20ER-FM	■	□			20,00	3,97	4,0
ZP 25ER-FM	■	□			25,00	4,76	4,7
ZP 32ER-FM	■	□			32,00	6,35	5,9
ZP 12ER-M		■	■	■	12,00	2,38	2,9
ZP 16ER-M		■	■	■	16,00	3,18	2,9
ZP 20ER-M		■	■		20,00	3,97	4,0

ISO	Materiály										Rozměry / Rozmery				
	M8310	M8345	8230	8240							d	s	d ₁		
ZP 25ER-M	■	■									25,00	4,76	4,7		
ZP 32ER-M	■	■									32,00	6,35	5,9		
ZP 16ER-R	■										16,00	3,18	2,9		
ZP 20ER-R	■										20,00	3,97	4,0		
ZP 25ER-R	■										25,00	4,76	4,7		
ZP 32ER-R	■	■									32,00	6,35	5,9		
ZP 40ER-R	■										40,00	7,94	7,0		
ZP 50ER-R	□										50,00	7,94	9,6		

NÁHRADNÍ DÍLY / NÁHRADNÉ DIELY

*) Uťahovací momenty viz strana / Uťahovacie momenty viď strana: 318 - 321.

Označení frézy Označenie frézy	Upínací šroub* Upínacia skrutka*	Šroubovák Skrutkovač	Podložka	Šroub podložky Skrutka podložky	Šroubovák Skrutkovač
SZP10	US 62004-T06P	FLAG T06P	-	-	-
SZP12	US 62506-T08P	FLAG T08P	-	-	-
SZP16	US 62508-T08P	FLAG T08P	-	-	-
SZP20	US 63510-T10P	FLAG T10P	-	-	-
SZP25	US 4011A-T15P	FLAG T15P	-	-	-
SZP32	US 65013-T20	SDR T20	-	-	-
SZP40	US 66015-T25P	SDR T25P	-	-	-
SZP50	US 68020-T30P	SDR T30	SZN 400322	US3508-T15P	FLAG T15P

ROVINNÉ FRÉZY
ROVINNÉ FRÉZYFRÉZY DO ROHU
FRÉZY DO ROHUVÁLCOVÉ/KOTUČOVÉ FRÉZY
VÁLCOVÉ/KOTUČOVÉ FRÉZYKOPIROVACÍ FRÉZY
KOPIROVACIE FRÉZYFRÉZY PRO SPEC. APLIKACE
FRÉZY PRE ŠPEC. APLIKÁCIEŘEZNÉ DOŠŤÍČKY
REZNÉ DOŠŤÍČKY

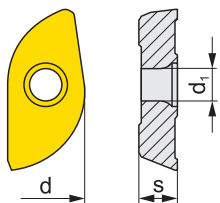

ZP



ZP-F



ZP-FM



ZP-M



ZP-R

VYMĚNITELNÉ BŘITOVÉ DESTIČKY / VYMENITELNÉ REZNÉ DOŠTIČKY

ISO	Materiály				Rozměry / Rozmery			
	M8310	M8345	8230	8240	d	s	d ₁	
ZP 20ER-F	■				20,00	3,97	4,0	
ZP 10ER-FM	■	■			10,00	1,70	2,2	
ZP 12ER-FM	■	■			12,00	2,38	2,9	
ZP 16ER-FM	■	■			16,00	3,18	2,9	
ZP 20ER-FM	■	□			20,00	3,97	4,0	
ZP 25ER-FM	■	□			25,00	4,76	4,7	
ZP 12ER-M		■	■	■	12,00	2,38	2,9	
ZP 16ER-M		■	■	■	16,00	3,18	2,9	
ZP 20ER-M		■	■		20,00	3,97	4,0	
ZP 25ER-M		■	■		25,00	4,76	4,7	
ZP 16ER-R	■				16,00	3,18	2,9	
ZP 20ER-R	■				20,00	3,97	4,0	
ZP 25ER-R	■				25,00	4,76	4,7	

NÁHRADNÍ DÍLY / NÁHRADNÉ DIELY

*) Uťahovací momenty viz strana / Uťahovacie momenty viď strana: 318 - 321.

Označení frézy Označenie frézy	Upínací šroub* Upínacia skrutka*	Šroubovák Skrutkovač
SZP10	US 62004-T06P	FLAG T06P
SZP12	US 62506-T08P	FLAG T08P
SZP16	US 62508-T08P	FLAG T08P
SZP20	US 63510-T10P	FLAG T10P
SZP25	US 4011A-T15P	FLAG T15P

